

DOCSIS Pre-Equalization: Vastly Powerful, Often Undervalued

An analysis of Cable Modem Pre-Equalization and Its Capabilities

A Technical Paper prepared for the Society of Cable Telecommunications Engineers
By

Brady Volpe

President & CTO

The Volpe Firm, Inc

3000 Old Alabama Rd., Suite 119-434,

Alpharetta, GA 30022, USA

Ph: +1-404-424-8202 x.201

brady.volpe@volpefirm.com

Overview

This paper will first provide a brief primer on DOCSIS to establish a baseline for the document. Next the paper will examine what is DOCSIS pre-equalization. How DOCSIS pre-equalization works and how DOCSIS pre-equalization can be extended. In the greater context of the paper, the reader must consider the implications of the extensions of DOCSIS pre-equalization. In section 5, details will be provided on how DOCSIS pre-equalization can be used to identify plant impairments and locate those impairments to within a few feet. This turns every cable modem in your network into a very powerful troubleshooting device. The implications are that DOCSIS pre-equalization as a troubleshooting tool will change the cable industries maintenance practices, significantly reduce maintenance costs and dramatically improve subscriber satisfaction with overall service performance, for data and video.

Volpe Firm, Inc

Contents

Section 1 – Overview

This paper will first provide a brief primer on DOCSIS to establish a baseline for the document. Next the paper will examine what is DOCSIS pre-equalization. How DOCSIS pre-equalization works and how DOCSIS pre-equalization can be extended. In the greater context of the paper, the reader must consider the implications of the extensions of DOCSIS pre-equalization. In section 5, details will be provided on how DOCSIS pre-equalization can be used to identify plant impairments and locate those impairments to within a few feet. This turns every cable modem in your network into a very powerful troubleshooting device. The implications are that DOCSIS pre-equalization as a troubleshooting tool will change the cable industries maintenance practices, significantly reduce maintenance costs and dramatically improve subscriber satisfaction with overall service performance, for data and video.

Section 2 – DOCSIS Primer

Data Over Cable Service Interface Specification (DOCSIS) is effectively a transparent Ethernet bridge over a hybrid fiber/coax (HFC) network. There are two (2) functional components in a DOCSIS network, the cable modem (CM) on the subscriber side and the CMTS in the headend or hub site. The CMTS communicates with the CMs on one or more 6 MHz wide (8 MHz in Euro-DOCSIS deployments), 64- or 256-QAM (quadrature amplitude modulation) digitally encoded RF signals on the downstream path of an HFC network between 108 and 1 GHz. The CMs communicate with the CMTS using one or more quadrature phase shift keying (QPSK), 8-, 16-, 32-, or 64-QAM digitally encoded RF signals, transmitted on an upstream HFC frequency between 5 to 85MHz. The digital data, transported via digitally modulated carriers, contains Media Access Control (MAC) information, which enables the CMs to coexist with other CMs by using a Time Division Multiple Access (TDMA) scheme or synchronous code division multiple access (S-CDMA). In essence, the CMTS is the system scheduler, which coordinates the power level, frequency, transmit time, and pre-equalization of all CM signals on the DOCSIS network.

By virtue of the fact that CMs and the CMTS are able to communicate digital data with each other over the HFC network for the purpose of “command-and-control” processes, they are also able to transmit packets containing other non-DOCSIS MAC related data. This is what fundamentally facilitates the ability to send Ethernet traffic bi-directionally over an HFC network. The CMTS-CM DOCSIS network transports IP based traffic in the same method that is used to communicate MAC protocol between the devices. Now that the IP traffic can traverse the HFC network, end users are also able to utilize this network for the purpose of transmitting content destined for the multitude of available data network services such as email, web browsing, IP video, and voice over IP telephony (VoIP).

In summary, each user is assigned a unique cable modem, which conforms to the DOCSIS standard. The CMTS works as a system scheduler enabling many cable modems to reside on the same RF network. TDMA and/or S-CDMA is employed in cable modem communications so that each modem is allocated a certain finite time over which it may transmit and receive IP data. IP data destined for a particular user is sent to that user's modem by the CMTS one or more downstream RF channel. This is the way an Ethernet network is able to be transparently bridged from a data backbone to a subscriber's home or business location.

Section 3 – What is DOCSIS Pre-Equalization

DOCSIS pre-equalization is a feature that was first added in the DOCSIS 1.1 standard. The objective of pre-equalization is to improve upstream performance in the presence of certain RF impairments. These impairments include, but are not limited to, frequency response, micro-reflections, and group delay.

The method in which DOCSIS pre-equalization improves upstream performance in the presence of these RF impairments is simple. The CMTS looks at messages coming from the cable modem and evaluates the signal quality of the messages. If the CMTS determines that the messages can be improved by pre-equalization, the CMTS sends equalizer adjustment values to the cable modem. The cable modem applies these equalizer adjustment values, called coefficients, to its pre-equalizer. The result is that the cable modem transmits a pre-distorted signal to compensate for impairments between the cable modem and the CMTS. As the pre-distorted signal traverses the HFC network it will experience the effects of RF impairments. By the time the pre-distorted signal from the cable modem arrives at the CMTS it will no longer have any of the original pre-distortion, as the RF impairments will have transformed it back into a near-ideal signal that the CMTS intended to see. If further adjustments are required, the CMTS will send more pre-equalizer coefficient values to the cable modem and the cycle repeats. This cycle repeats at least once every thirty seconds for every cable modem in the DOCSIS network, provided pre-equalization is enabled in the CMTS.

An illustration of a cable modem signal is perhaps the best way to demonstrate pre-equalization in action. Figure 1 below shows an upstream cable modem signal as seen at the CMTS. This RF signal shows significant roll-off due to plant impairments. This would cause the CMTS to have difficulty-demodulating signal, resulting in codeword errors, lost subscriber data and poor subscriber quality of experience (QoE).

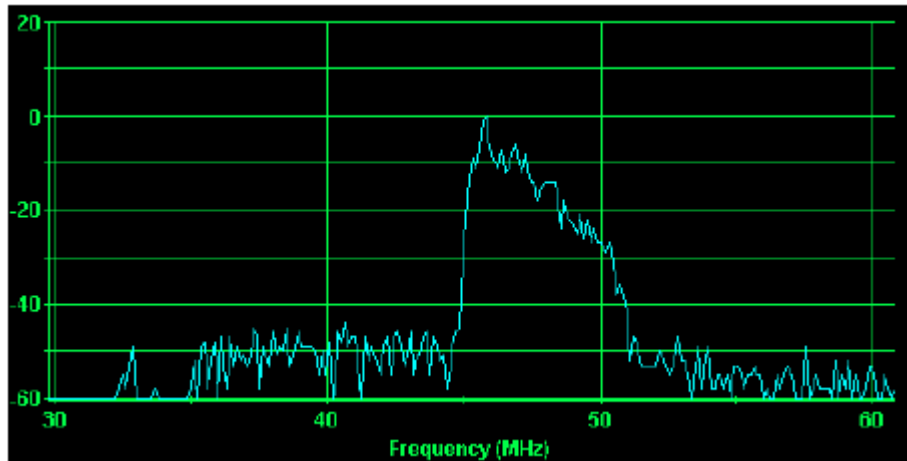

Figure 1: Cable Modem Signal without Pre-Equalization

Once DOCSIS pre-equalization is enabled on the CMTS for this particular upstream, the CMTS will instruct the cable modem to pre-distort the signals it is transmitting via its internal equalizer. The pre-distortion would result in a signal that has higher output at the high frequencies and less output at the lower frequencies. This would be a mirror image of the signal seen in figure 1. The result is the response shown in figure 2 below, where the signal at the CMTS is flat after going through the RF impairments.

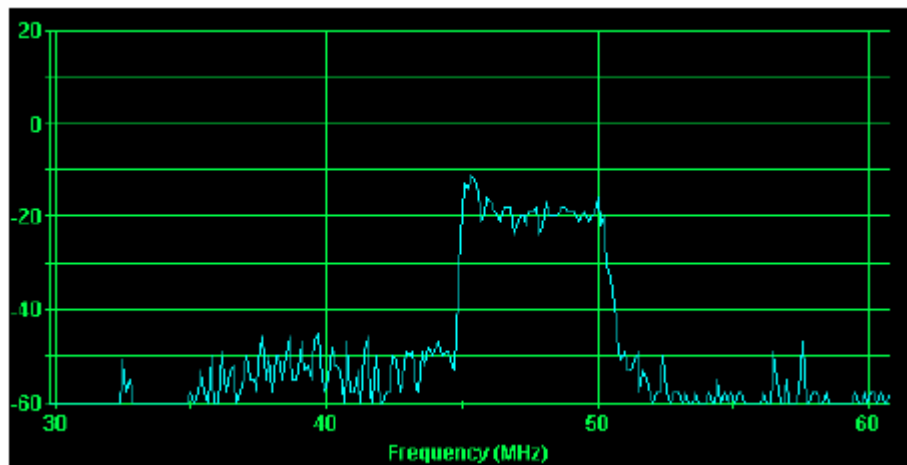

Figure 2: Cable Modem Signal with Pre-Equalization

Now the value of DOCSIS pre-equalization should be clear. What was once a very poor, looking signal at the CMTS (figure 1), is now a near-perfect signal at the CMTS (figure 2) thanks to pre-equalization in the cable modem.

Enabling Pre-Equalization in the CMTS

DOCSIS pre-equalization can have a 5-10 dB SNR (MER) improvement in the upstream for the majority of DOCSIS cable modems if they are DOCSIS version 2.0 and higher. However

the CMTS must be configured to take advantage of this feature. Enabling DOCSIS pre-equalization is simple and usually is a one line command in Cisco, Arris and Casa CMTSs. Here are example commands for each CMTS:

Cisco CMTS Example:

```
cable upstream 0 modulation-profile 143 142
cable upstream 0 equalization-coefficient
no cable upstream 0 shutdown
```

The Cisco command for pre-equalization is highlighted in blue. It is 'cable upstream <n> equalization-coefficient', where <n> is the upstream channel to enable pre-equalization.

Arris CMTS Example:

```
interface cable-upstream 4/14.0
cable channel-id 15
cable pre-eq-enable true
cable modulation-profile 223
cable docsis-mode atdma
no shutdown
```

Again the Arris command for pre-equalization is highlighted in blue and is 'cable pre-eq-enable true'. This must be issued under each interface cable-upstream.

Casa CMTS Example:

```
interface upstream 1/0.1
frequency 38500000
channel-width 3200000
ingress-cancellation 300
logical-channel 0 profile 6
logical-channel 0 minislot 2
logical-channel 0 pre-equalization
no logical-channel 0 shutdown
no shutdown
```

Finally, the Casa example is shown in blue. The line required is 'logical-channel <n> pre-equalization', where <n> is the upstream of the desired channel.

In all examples it should be noted that enabling pre-equalization is done in the CMTS and it is a one-line command per upstream channel. Enabling pre-equalization is not service affecting, though there are some precautions that should be taken and discussed in advance with your DOCSIS network expert.

Once enabled, you should expect to see significant performance improvements in upstream SNR (MER) for every upstream port enabled with pre-equalization.

Section 4 – How Exactly Does DOCSIS Pre-Equalization Work?

To understand how DOCSIS pre-equalization works we must understand the difference between a mainline tap and an equalizer tap. In HFC networks mainline taps are used to distribute signals on drop cables to subscribers homes. This terminology for tap must not be confused with same name of tap that is used when discussing equalizers. They are completely separate terms and will lead to great confusion unless this point is made clear.

A time delay element, two gain blocks and a summation of the signals as follows in figure 3 can define two equalizer taps.

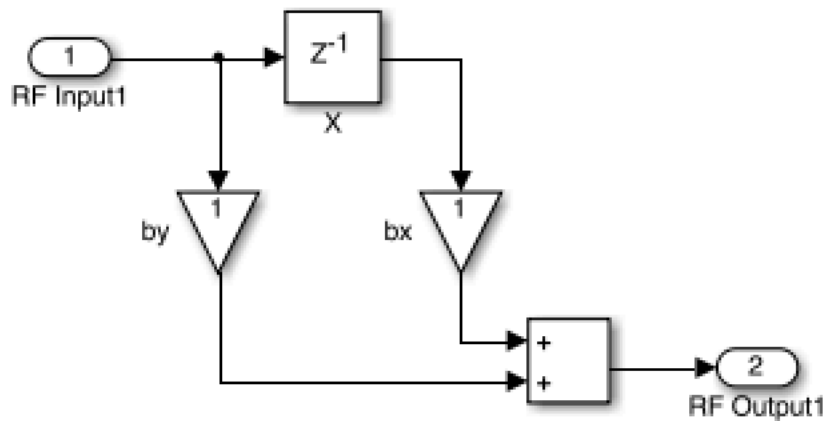

Figure 3: Simple Equalizer Taps

At first this may look complicated, but it is actually simple. A DOCSIS signal from the cable modem will enter at port 1, RF Input1. If the CMTS has told the cable modem to disable the amplifier gain in 'bx' and enable the amplifier to full gain in 'by', then the signal will go through the main "tap" of figure 3 without any changes. The main tap is the amplifier with gain 'by'.

On the other hand, if the CMTS tells the cable modem to attenuate amplifier 'by' and turn on the 'bx' amplifier, then signals will be forced to go through the second tap leg of figure 3. This tap leg has a delay line in it. The delay line in this tap leg will cause some of the signals to be delayed and then amplified. At the same time, signals will be allowed to pass through amplifier 'by', the main tap, and have a different level of amplification. The output of both amplifiers (the main tap and the secondary tap) will be added together in the summation block. This is the block with two "+" marks on it. Then the signal will be transmitted to the CMTS.

This two-tap example will have little impact on an upstream DOCSIS channel since it only has one delay tap. Starting with DOCSIS 1.1 eight (8) taps were added to DOCSIS cable modems. It was quickly realized that eight (8) taps were not enough to have substantial improvement on the upstream. So the DOCSIS 2.0 and 3.0 standards added 24 taps to cable modems. This provides substantial control over the upstream frequency, even at a bandwidth of 6.4 MHz to make significance improvements in the presence of RF impairments.

The equalizers with 24 taps are significantly more complex than the two-tap equalizer shown in figure 3. Figure 4 below shows a rough outline of a 24-tap equalizer architecture. Note that this equalizer is not drawn with all 24 taps as it would not easily fit on the size page of this document and still be readable. However one should get a better concept of the complexity of the pre-equalization circuitry that is built into every DOCSIS 2.0 and greater cable modem.

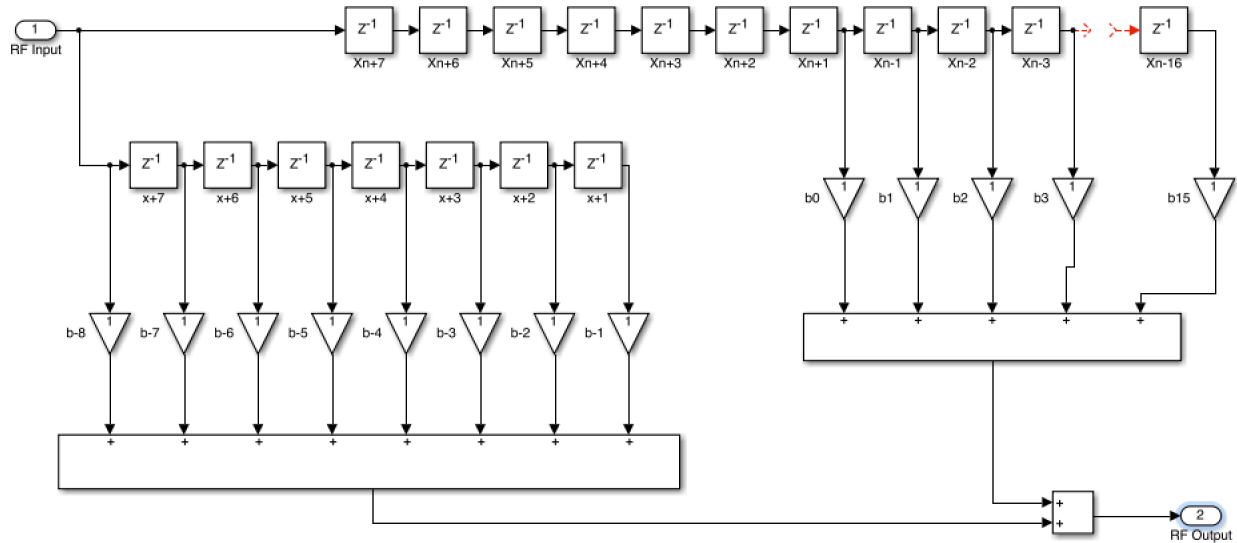

Figure 4: DOCSIS 24-Tap Conceptual Architecture

There are two sections in the architecture of figure 4. The lower left bank of taps is called pre-main tap taps. There are seven pre-main tap taps in a DOCSIS cable modem and will be observed later in the paper. The top right section consists of the main tap, which is the first gain block labeled **b0**. The main tap is an important tap since, as described previously, if there are no RF impairments, then all signals will traverse through this stage. So this tap should ideally have a lot of RF energy going through it at all times and thus have the highest value. The remaining taps are called the post-main tap taps. There are 16 post-main tap taps in DOCSIS cable modems (DOCSIS 2.0 and higher). When energy is observed in these taps it indicates that RF impairments such as micro-reflections are present and the CMTS is activating the gain states to compensate for these impairments. The higher the value of energy in the post-main taps the greater the impairment.

The actual tap values can be displayed by querying the SNMP pre-equalization coefficient string in the cable modem. Once this string is obtained it is graphed in figure 5 below showing the levels of the tap values described thus far:

Upstream Pre-Equalization Coefficients

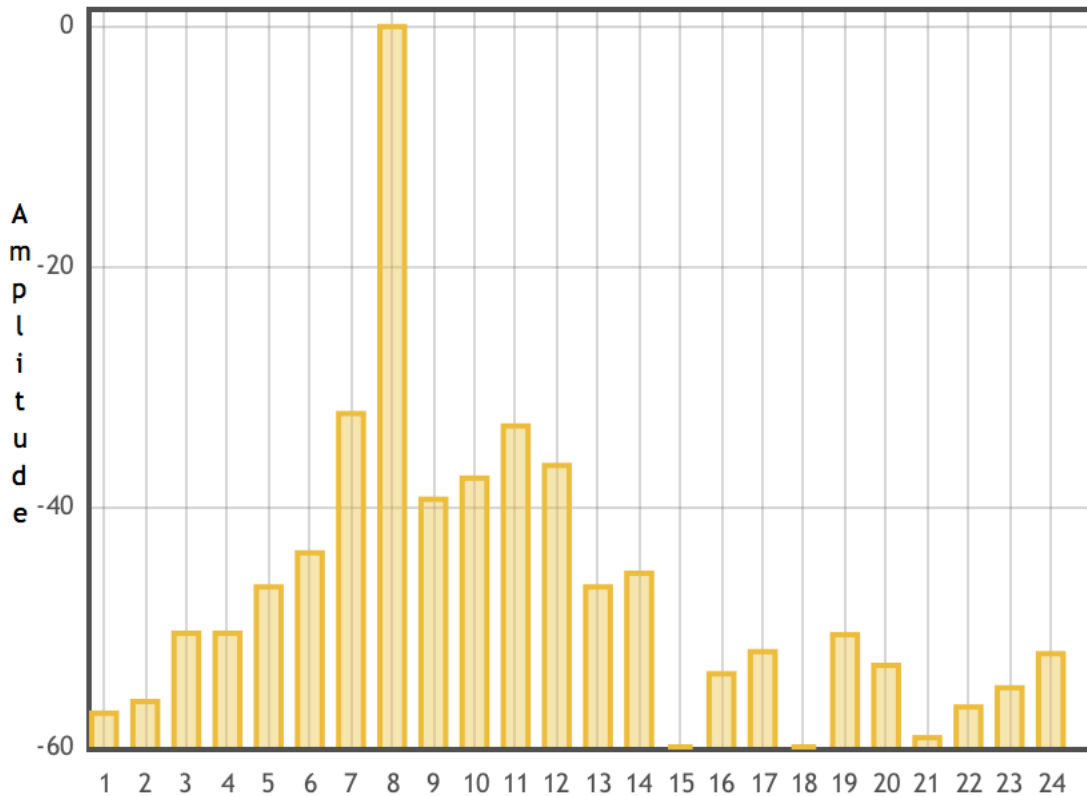

Figure 5: DOCSIS Pre-Equalization Tap Values

The main tap is shown at position eight (8) on the x-axis. As discussed it has the highest energy level. The pre-tap taps are at positions one (1) through seven (7) and often indicate the presence of group delay. The post-main tap taps are at positions nine (9) through 24. It is the post-main tap taps (postMTT) that provides the most valuable information in troubleshooting a DOCSIS network. This will be discussed in the next section.

From this section you should have a clear understanding of the difference between a mainline tap and pre-equalizer tap. You should also have a much better understanding of how a pre-equalizer works in addition to how the individual taps can be visualized.

Section 5 – What Else Can DOCSIS Pre-Equalization Do?

So far this paper has discussed how DOCSIS pre-equalization can help overcome upstream impairments and how pre-equalization works. Overcoming upstream impairments is a great feature unto itself. However by analyzing the pre-equalization coefficients one can learn much more about the DOCSIS upstream.

Two key things that can be observed by looking at pre-equalizer coefficients are the type of impairments in the upstream that the equalizer is attempting to overcome and the estimated distance to the impairment.

Why might this information be useful? If every cable modem is analyzed on a cable plant for impairments, this information can be extremely powerful. Groups of cable modems can be identified as having common problems, such as micro-reflections or group delay. This same group of cable modems can provide the estimated distance to the impedance mismatch causing the micro-reflection. By mapping this distance, pinpointing the exact location is possible. This enables the cable operator to dispatch a technician directly to the location of a problem (minimizing MTTR) with prior knowledge of what to look for – an impedance mis-match, such as a corroded cable.

Two things have occurred. First, the cable operator identified a problem possibly before subscribers complained about the issue or even noticed it. Second, the cable operator was able to dispatch a technician to the exact location of the problem. Then once the problem is fixed the cable operator can verify the repair by reviewing the reports from the cable modem pre-equalization data. This really changes everything!

How is all of this accomplished? A mathematical function called a complex Fast Fourier Transform (FFT) is performed. The FFT is just a complicated sounding term for some math functions that translate the time domain to the frequency domain or vice versa. The FFT is implemented on the cable modem equalizer coefficients. This produces a frequency response of the upstream impairments like the one shown in figure 6.

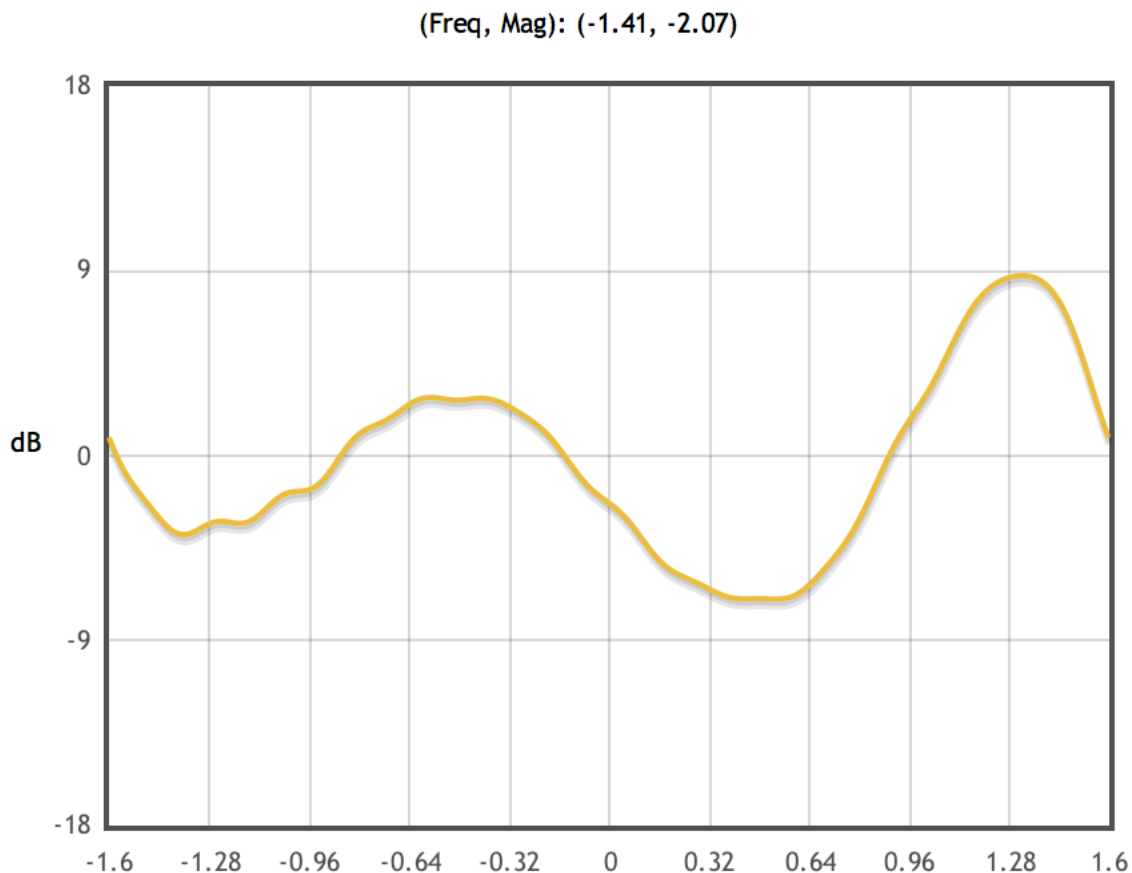

Figure 6: Frequency Response from Pre-Equalization Data

This frequency response shows a cable modem that is staying online, but is making up for a severely impaired upstream. The frequency response of the upstream is nearly 18 dB peak-to-valley. DOCSIS has an upstream requirement of 0.5 dB peak-to-valley, so this upstream does not meet the DOCSIS requirements. Fortunately pre-equalization is making up for the difference.

After performing a complex FFT on the data additional information is made available as shown in figure 7:

Severity	Idx	CM MAC Address	IP Address	MTC (dB)	NMTER (dB)	preMTTTR (dB)	postMTTTR (dB)	MRLevel (dBc)	Delay (ns)	TDR (feet)
⊗	0	33:92:16:86:17:14		0.068	-18.096	-26.051	-18.854	-15.93	5019.531	67.7
⊗	1	98:68:95:25:36:32		0.097	-16.564	-34.912	-16.628	-16.112	389.000	87.5
⊗	2	13:24:75:47:34:91		0.058	-18.776	-26.954	-19.493	-16.535	1181.066	72.0
⊗	3	32:27:14:24:77:81		0.079	-17.440	-25.797	-18.125	-17.03	389.000	183.4
⊗	4	42:32:82:43:64:98		0.066	-18.241	-23.493	-19.780	-17.395	389.000	49.3

Figure 7: Pre-Equalization Table After Complex FFT

Figure 7 shows the MAC address of 32:27:14:24:77:81, highlighted in blue whose frequency response is shown in figure 6. (Note that the MAC address is fictitious for privacy reasons.) In this particular case, there are three columns to focus on, postMTTTR, MRLevel and TDR. postMTTTR (Post-Main Tap to Total Energy Ratio) tells us that there is a strong probability that a micro-reflection exists in the return path. This is the likely reason that the frequency response in figure 6 is so bad.

The MRLevel (micro-reflection level) provides an estimate of the level in dBc of the micro-reflection based upon the peak postMTTTR location.

The TDR (time domain reflectometer) provides an estimate in feet to the location of the source of the micro-reflection. In the case of 183.4 feet, this micro-reflection is likely located close or near to the tap feeding the house. Some other low value numbers under TDR in figure 7 indicate that cable modems with high micro-reflection levels are likely due to in-home wiring problems.

There are many examples where the TDR will show spans of 500 to 2000 feet, in which case many cable modems will be impacted, as this is a case of outside plant. An example of this is shown in figure 8 [14], where the three red dots on the map indicate cable modems with common upstream impairments mapped.

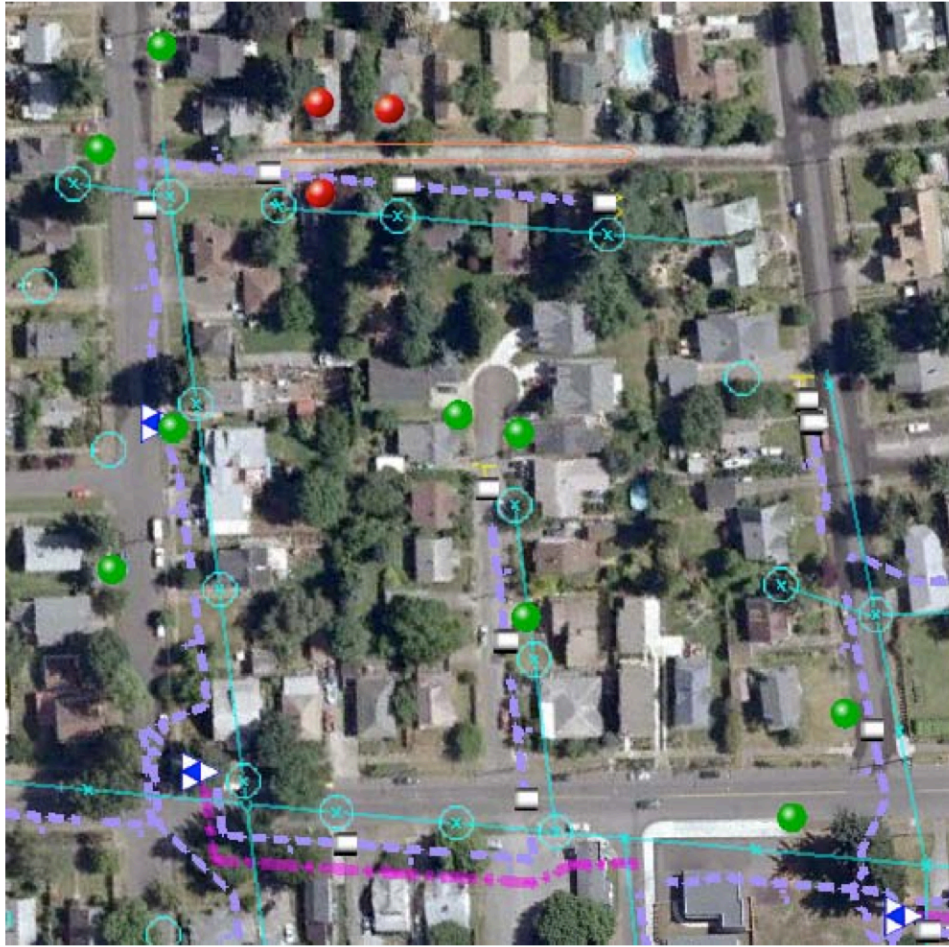

Figure 8: Mapping Upstream Impairments Based on Pre-Equalization

Comprehensive applications are available that collect cable modem DOCSIS pre-equalization data, perform the analysis and identify upstream impairments based on the data. One such example application can be seen in figure 9 and is meant to give the reader a concept of the application. A number of major MSOs currently have in-house systems similar to the application in figure 9 that integrate with their back-office systems.

Nimble This

Proactive Cable Resources

Dashboard ▾ Data ▾ Config ▾ Help

You are logged in as: Brady Volpe

Upstream Frequency: 3.2MHz

Reload All: Found Records: 524/ 11/ 213/ 300/ 0 < > 3

DOCSIS Equalization Analysis

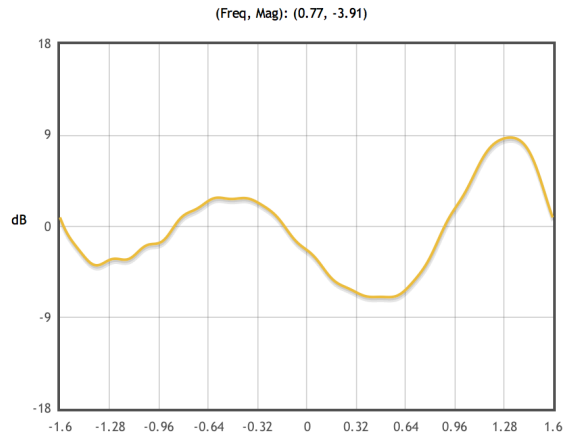
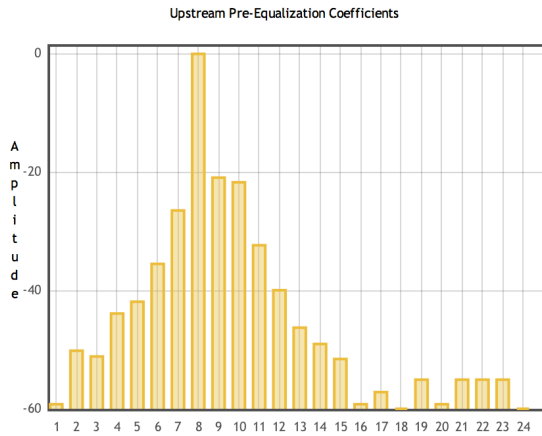

Severity	Idx	CM MAC Address	IP Address	MTC (dB)	NMTER (dB)	preMTTER (dB)	postMTTER (dB)	MRLevel (dBc)	Delay (ns)	TDR (feet)
✖	0	33:92:16:86:17:14		0.068	-18.096	-26.051	-18.854	-15.93	5019.531	67.7
✖	1	98:68:95:25:36:32		0.097	-16.564	-34.912	-16.628	-16.112	389.000	87.5
✖	2	13:24:75:47:34:91		0.058	-18.776	-26.954	-19.493	-16.535	1181.066	72.0
✖	3	32:27:14:24:77:81		0.079	-17.440	-25.797	-18.125	-17.03	389.000	183.4
✖	4	42:32:82:43:64:98		0.066	-18.241	-23.493	-19.780	-17.395	389.000	49.3
✖	5	50:53:88:19:73:18		0.033	-21.233	-22.132	-28.516	-18.055	0.000	167.1
✖	6	77:10:69:41:88:32		0.048	-19.574	-35.542	-19.685	-18.419	5283.717	116.6
✖	7	22:68:47:54:88:74		0.055	-19.018	-38.086	-19.072	-18.425	0.000	81.1
✖	8	80:16:30:50:42:81		0.055	-19.006	-19.726	-27.163	-18.703	0.000	167.1
⚠	9	69:32:75:24:50:65		0.019	-23.586	-25.511	-28.048	-19.072	0.000	167.1

Showing 1 to 10 of 524 entries

◀ Previous Next ▶

Copyright 2013 All Rights Reserved - Nimble This LLC :: Powered by CableLabs

Figure 9: Proactive Network Maintenance Application for Pre-Equalization Analysis

Section 6 – Summary

This paper examined pre-equalization, what it is, how it works, why it useful, and how it can be further utilized. The reader should be able to take away a sense of the value of DOCSIS pre-equalization. For some time it has been deployed in DOCSIS networks to improve upstream performance, but only recently has it been used as a method to proactively troubleshoot the DOCSIS network. This will have substantial impacts on DOCSIS and HFC networks moving forward.

Combined with full-band capture modems, the utilization of pre-equalization coefficients to proactively troubleshoot networks will change cable network maintenance for evermore in a very positive way. First, the test equipment and monitoring requirements will be impacted. There will be a dramatic decrease on the dependency of sweep and maintenance technician tools in the industry. Next, the ability of cable operators to have early identification of plant impairments will be dramatically improved. Upon early identification, cable operators will have knowledge of the exact location of impairments; dramatically reducing time spent looking for impairments in the normal divide and conquer methods of troubleshooting. These legacy methods are expensive and often result in poor quality of experience to the subscriber.

The industry is close to a new day where the tools currently in development are widely adopted and accepted as required applications. The applications discussed in this document.

Volpe Firm, INC

Bibliography

- [1] CableLabs, "Data Over Cable Service Interface Specifications DOCSIS 3.0-Physical Layer Specification," CM-SP-PHYv3.0-I08-090121, 2009.
- [2] B. Currivan, "Cable modem physical layer specification and design," in Cable Modems: Current Technologies and Applications , IEC Compendium and IEEE Press, 1999.
- [3] S. Haykin, Adaptive Filter Theory. Englewood Cliffs, NJ: Prentice Hall, 1991.
- [4] A. H. Sayed, Fundamentals of Adaptive Filtering. Hoboken: Wiley-IEEE Press, 2003.
- [5] T. Wolf and C. L. A. Gatherer, "Low complexity equalization for cable modems," in IEEE Proc. ISCAS, May 1998, vol. 5, pp. 522–524.
- [6] A. Gatherer, "The effect of microreflections on decision feedback equalization," IEEE Trans. Signal Process., vol. 54, no. 1, pp. 228–231, Jan. 1997.
- [7] Y. Kim, Y. Kim, Y. Lee, W. Oh, and W. Kim, "Synchronization and channel equalization for upstream cable modem," in IEEE Proc. ISCE Symp., Apr. 2008, pp. 1-4.
- [8] L. J. D'Luna et al., "A single-chip universal cable set-top box/modem transceiver," IEEE J. Solid-State Circuits, vol. 34, no. 1, pp. 1647–1660, Nov. 1999.
- [9] M. P. Sellars, J. Porter, S. D. Greaves, J. J. Wassell, A. Hopper, and W. J. Fitzgerald, "Performance of fast start-up equalizer for broadband indoor radio," IEE Proc. Comm., vol. 148, no. 1, pp. 49–56, 2001.
- [10] G. Ysebaert, K. Vanbleu, G. Cuypers, M. Moonen, and T. Pollet, "Combined RLS-LMS initialization for per tone equalizers in DMT-receivers," IEEE Trans. Signal Process., vol. 51, no. 7, pp. 1916–1927, 2003.
- [11] G. H. Lee, J. Choi, R. H. Park, I. Song, J. H. Park, and B. U. Lee, "Modification of the reference signal for fast convergence in lma-based adaptive equalizers," IEEE Trans. Consum. Electron., vol. 40, no. 3, pp. 645–654, 1994.
- [12] G. Wang and R. Kraemer, "Low-complexity initialization of adaptive equalizers using approximate channel inverse," in IEEE Symp. Signal Process. Inf. Technol., Dec. 2005, pp. 694–698.
- [13] J. Wang and J. Speidel, "Packet acquisition in upstream transmission of the DOCSIS standard," IEEE Trans. Broadcast., vol. 49, no. 1, pp. 26–31, Mar. 2003.
- [14] CableLabs, "DOCSIS® Best Practices and Guidelines, Proactive Network Maintenance Using Pre-equalization", CM-GL-PNMP-V02-110623, 2011

Abbreviations and Acronyms

Adaptive pre-equalizer A circuit in a DOCSIS 1.1 or newer cable modem that pre-equalizes or pre-distorts the transmitted upstream signal to compensate for channel response impairments. In effect, the circuit creates a digital filter that has approximately the opposite complex frequency response of the channel through which the desired signal is to be transmitted.

Cable Modem (CM) A modulator-demodulator at subscriber locations intended for use in conveying data communications on a cable television system.

Cable Modem Termination System (CMTS) Cable modem termination system, located at the cable television system head-end or distribution hub, which provides complementary functionality to the cable modems to enable data connectivity to a wide-area network.

Channel A portion of the electromagnetic spectrum used to convey one or more RF signals between a transmitter and receiver.

Coefficient Complex number that establishes the gain of each tap in an adaptive equalizer.

Customer Premises Equipment Equipment at the end user's premises; may be provided by the end user or the service provider.

dBc Decibel below carrier

Downstream In cable television, the direction of transmission from the head-end to the subscriber.

Fast Fourier transform (FFT) An algorithm to compute the discrete Fourier transform (DFT), typically far more efficiently than methods such as correlation or solving simultaneous linear equations.

Fiber Node In HFC, a point of interface between a fiber trunk and the coaxial distribution.

Frequency response A complex quantity describing the flatness of a channel or specified frequency range, and that has two components: amplitude (magnitude)-versus-frequency, and phase-versus-frequency.

Group Delay The difference in transmission time between the highest and lowest of several frequencies through a device, circuit or system.

Micro-reflection A short time delay echo or reflection caused by an impedance mismatch. A micro-reflection's time delay is typically in the range from less than a symbol period to several symbol periods.

MRLevel Micro-reflection level

Modulation error ratio (MER) The ratio of average symbol power to average error power. The higher the MER, the cleaner the received signal.

postMTT Post main tap tap

postMTTR Post-Main Tap to Total Energy Ratio

Pre-equalizer See *adaptive pre-equalizer*.

SNR signal-to-noise ratio

Tap (1) In the feeder portion of a coaxial cable distribution network, a passive device that comprises a combination of a directional coupler and splitter to "tap" off some of the feeder cable RF signal for connection to the subscriber drop. So-called self-terminating taps used at feeder ends-of-line are splitters only and do not usually contain a directional coupler. Also called a multitap. (2) The part of an adaptive equalizer where some of the main signal is "tapped" off, and which includes a delay element and multiplier. The gain of the multipliers are set by the equalizer's coefficients. (3) One term of the difference equation in a finite impulse response or a infinite impulse response filter. The difference equation of a FIR follows: $y(n) = b_0x(n) + b_1x(n-1) + b_2x(n-2) + \dots + b_Nx(n-N)$

TDR Time domain reflectometer

Upstream The direction from the subscriber location toward the head-end.